

AXM-II

OPERATION MANUAL

PLEASE READ THIS MANUAL VERY CAREFULLY BEFORE OPERATING

Information Before First Use	3
Product Specifications	3
KEYBOARD LAYOUT AND DESCRIPTION	4
Keyboard	5
Instructions	6
Select weight units	6
Tare Setting	7
How to cancel the tare value	7
Disabling the Auto Tare Function	8
Accumulation Function (M+)	8
Storing Weighing Results into Memory:	8
Memory Recall Mode:	8
Clearing All Accumulated Results:	8
Deleting a Specific Accumulated Entry:	8
Counting Mode	9
Check Weighing Function	9
Percentage Weighing	11
RS-232 Connection (D-sub 9 pin female connector)	12
Internal Setting Function	12
Function Definitions and Parameter Settings	15
Maintenance and Care Guidelines	24

Information Before First Use

Thank you for purchasing a UWE product, please read this manual carefully before starting to use it. The product packaging should contain the following items:

Your product package should contain the following items:

- AXM-II scale x 1
- Power adaptor x 1

If any item is missing or damaged, please contact your dealer for assistance.

- Place it in a stable environment, rotate the adjustment feet, refer to the level bubble (if any), and adjust to a level position.
- Built-in rechargeable battery, please charge in a timely manner until the indicator light turns green to maintain optimal battery performance.
- Please use the power adapter provided by the original factory for charging. Unauthorized power adapters may shorten the battery life and damage electronic components.
- Charge the scale before using it for the first time.
- When using for the first time, please ensure that the weight and sense settings on the display screen are the same as the specifications marked on the panel (or data plate).
- Do not use this scale in areas with high winds, significant vibrations, or strong magnetic influences.
- Please use within the recommended temperature range and avoid humid environments.
- Recharge the battery immediately when the low battery indicator appears.
- If needed, clean with a damp cloth but avoid excessive moisture.
- After use, please turn off the power and store it in a dry and cool place.

Please avoid using it in bad environments.

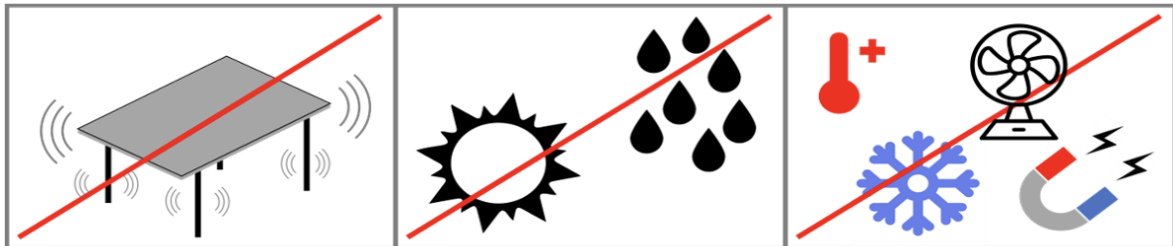

Product Specifications

The AXM-II Digital Weighing Scale has OIML approval (($n \leq 3000, 6000, 3000 \times 2$ (Dual-Interval)). It offers high precision 30,000 (60,000) divisions, with other division numbers that can also be set. We also accept customized models with higher precision. (Max $n=150,000d$).

The table below provides specific model specifications:

Model	Capacity	Readability	Non-OIML Readability (+/- 2d error)	Platter Size (mm)	Setup
AXM-II	1.5/3 kg	0.5/1 g	0.1 g	280 x 330	Dual interval
AXM-II	3/6 kg	1/2 g	0.2 g	280 x 330	Dual interval
AXM-II	6/15 kg	2/5 g	0.5 g	280 x 330	Dual interval
AXM-II	15/30 kg	5/10 g	1 g	280 x 330	Dual interval

Other General Specifications Include:

- Tare range: Full tare range
- Initial Zero range: $\pm 20\%$
- Manual Zero range: $\pm 2\%$
- Display: 6-digit LCD, height 18 mm
- Power supply: Rechargeable battery or three AA batteries; charger (DC 9~12V, 500mA)
- Temperature and humidity: 10°C~40°C (recommended to use in a constant temperature environment), 25%~85% RH
- Display update rate: AD conversion speed 1~10 times (multi-level selectable); about 10 or 50 times/second
- Construction: Compact size with durable and robust construction

**Please note that specifications are subject to change without notice.

KEYBOARD LAYOUT AND DESCRIPTION

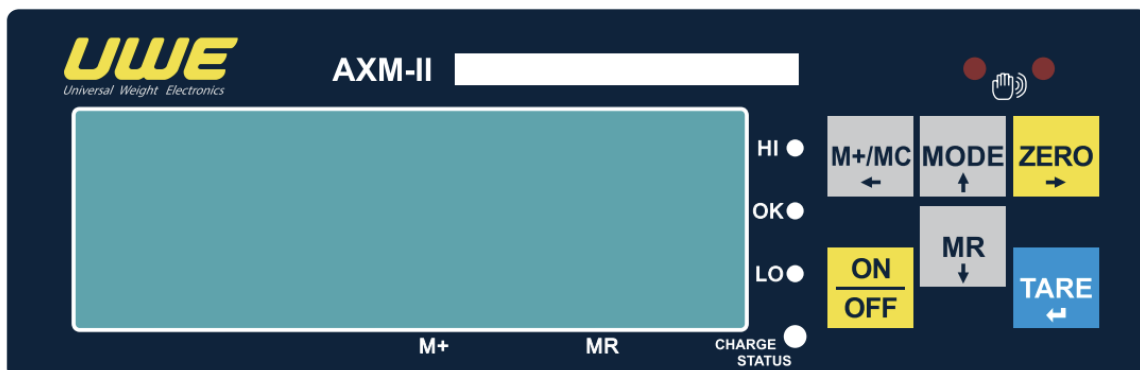

Symbol/Indicator	Description
ZERO	Indicates that the current measurement state is at the 'true zero point'.
NET	Indicates that the current display value is the net weight value (for example, the container weight has been deducted).
(Stable)	No dedicated symbol, when the result is in an unstable state, it is indicated by flashing the measurement unit symbol.
Battery	Four bars + the battery frame, showing the five-level battery capacity, when the battery symbol frame flashes, it should be charged immediately.
Measurement Unit	Represents the current unit of measurement used by this electronic scale; possible settings include metric units (kg for kilograms or g for grams), imperial units (lb for pounds), or quantity (PCS for pieces).
(M+)	Indicates that there is value accumulation in the internal memory.
(MR)	No dedicated symbol, when it is in the re-display state, it is indicated by flashing the display screen.
HI-OK-LO	Prompt the difference (comparison) state between the over-weight object on the scale pan and the preset value.
Charging status	Red indicates that the battery is being charged, green indicates that the charging is completed.
IR Sensor 	For settings related to the IR Sensor, refer to the internal setting menu F51. This will guide you on sensor activation and setting.

Keyboard

Key	Function
ON/OFF	Press this button to turn on the scale. If you want to turn off the scale, press and hold this button for more than 0.5 seconds.
ZERO ⇐	Use this key to reset the display value to zero, but make sure you're within the specified zero range. In the parameter setting mode, this key allows you to move right to set the position or exit the main menu.
TARE	This button serves the crucial function of taring, or excluding the weight of the container. A long press on this button initiates the pre-set tare mode. In the parameter setting mode, this key acts as a confirm key and moves down or decreases the value by 1.

MODE ↑	<p>This versatile key allows you to switch the weight unit from metric to Imperial (when this unit is enabled) or between different units when you're in the standby screen.</p> <p>A long press activates and sets the check weighing mode, allowing you to set upper and lower limits.</p> <p>In the parameter setting mode, this key allows you to move up or increase the numerical position by 1.</p>
M+/MC ⇐	<p>This key is used to submit the weighing result and save it (accumulate into the internal memory) when the accumulation function is enabled (F11=on). If the MR key is in the weight display mode, you can press this key to clear the stored data.</p> <p>In the parameter setting mode, this key lets you move left to the setting position and acts as the confirm key.</p>
MR ↓	<p>This key is used to retrieve the accumulated total weight result from the internal memory.</p> <p>In the parameter setting mode, it lets you move down or decrease the numerical value by 1, or move left.</p>

Instructions

- Place this scale on a solid flat surface, make sure that the environment has no strong wind/vibration/radio interference.
- Adjust the four adjustment feet according to the status of the bubble level, make sure to adjust to a horizontal position
- Make sure that the weighing pan is empty, turn on the machine and wait for the numbers on the display screen to count down to 0 value (self-check),
- Make sure that the display screen is in zero weight state (show zero point and stable indicator), indicating that the machine is ready to use after turning on.
- If the weight display value is not zero, press [ZERO ⇐] key to set the display value to zero
- If you cannot zero, please change the location (avoid interference sources) and repeat previous steps

Select weight units

Press the [MODE] key to switch between metric/imperial/...PCS and other measurement units.

PS. This must be used in conjunction with the advanced settings F5 use unit menu to turn on/off the available measurement units.

Tare Setting

To Change Tare Setting:

1. Access the internal setting F9 to change Tare options, or during weighing mode, long-press [TARE] to enter the menu and switch between Tare options.
2. Use the [↑] key to change options.
3. Confirm your selection by pressing [TARE] key.

Tare Mode	Description
Manual Tare (tr.oFF)	Press [TARE] after placing a load to reset the display to zero (Net weight). NET indicator shows net weight value.
First Auto Tare (tr.on)	Automatically tares the first stable weight placed on the scale. If "auto print" and "auto accumulate" are set, the second weight is stored and printed automatically.
Continuous Auto Tare (tr.Cnt)	Automatically tares each stable weight placed on the scale. If check weighing function is enabled, auto tare is performed when the result falls within the acceptable range.
Package Tare (tr.Pack)	Automatically tares the first stable weight placed on the scale. Auto tare activates when check weighing function is enabled and the measured item falls within the acceptable weight range.

How to cancel the tare value

Action	Manual Tare Mode	Auto Tare Mode
Step 1: Clear the scale	Remove all items from the scale	Remove all items from the scale
Step 2: Wait for negative value and stability	Wait for the scale to display a negative value and stability symbol	The scale will automatically stabilize and display a zero value
Step 3: Clear the tare value	Press the [Tare] key. The disappearance of the NET symbol indicates the tare value has been cleared	The scale will automatically clear the tare value, evidenced by the NET symbol turning off
Step 4: Zero the display	If >0< symbol is not visible, press the [Zero] key to reset the display	If >0< symbol is not visible, press the [Zero] key to reset the display

Disabling the Auto Tare Function

Step	Action
Step 1	Long press the [TARE] key to access the tare mode menu
Step 2	Select the [tr.oFF] option
Step 3	Press [TARE] to turn off all auto tare functions



Accumulation Function (M+)

Before you begin, remember the Accumulation Function can only be activated when the F11/ACC is ON. Ensure that the unit of measurement is consistent throughout. Clear accumulated values after unit conversion. The accumulation function can accommodate up to 999 entries or a total accumulated value of 999,999.

Prerequisites:

1. The Accumulation Function can only be activated when the F11/ACC is set to ON.
2. The same unit of measurement must be used for all weighings.
3. The Accumulation Function can accommodate up to 999 entries or a total value of 999,999.

Storing Weighing Results into Memory:

1. Place your load on the scale. Wait for the "stable" indicator  to appear on the display.
2. Press the [M+/MC] button. Your weight result is now stored in the memory. A  symbol will appear, and the screen will briefly show the total number of entries (t=xxx) and the total accumulated value.
3. Remove the load and ensure the display returns to zero before repeating these steps for additional weighings.

Memory Recall Mode:

1. In standby mode, press the [MR] button. The display will start flashing, showing the total entries (t=xxx) and the total accumulated value alternately.
2. Press [MR] again to show "P=001" and the weight value of the first entry. Pressing [MR] additional times will display subsequent entries in a similar fashion.
3. To exit Memory Recall Mode, press the [Tare] button.

Clearing All Accumulated Results:

In Memory Recall Mode, press the [M+/MC] button. This will erase all accumulated data, and the  symbol will disappear.

Deleting a Specific Accumulated Entry:

1. In Memory Recall Mode, press the [MR] button until the desired entry is displayed.

2. Press the [M+/MC] button to erase that specific entry. The total number of entries will decrease by one.
3. To exit Memory Recall Mode, press the [Tare] button.

Counting Mode

Use the counting mode to determine the number of pieces placed on the scale based on the weight of a sample batch.

Step	Operation	Display/Indicator
1	Make sure the scale is at zero	Displays "0"
2	If a container is present, press [TARE] to eliminate its weight	Displays "0"
3	Choose 'PCS' as your unit of measurement by pressing [MODE]	Unit of measurement shows "PCS"
4	Initiate the sampling mode by long pressing [ZERO⇒]	Displays "S---"
5	Input the quantity of pieces in your sample batch. Increase the quantity with [MODE⇑], decrease with [MR⇓], and shift to the next digit with [ZERO⇒]	The input quantity is displayed
6	Put the sample batch on the scale	'OK' indicator lights up
7	Confirm the setting and leave the sampling mode by pressing [TARE]	The display shows the quantity of the sample batch
8	Start using the counting function by placing the items to be counted on the scale	The display shows the quantity of the items based on their total weight

Notes:

- In counting mode, [MODE⇑] and [MR⇓] function as the increasing and decreasing keys when setting the sampling quantity.
- If an item is added or removed from the platter after sampling, the display will update to show the current count number.
- If no item is placed on the scale or if the weight is too light, the 'Lo' indicator will light up.
- If the total weight of the items on the scale is less than 20d, the PCS unit symbol will flash as a warning.

- If the unit weight of the items is too light (less than 0.5d per unit), the PCS unit symbol will also flash as a warning.

Check Weighing Function

Activation/Deactivation

Step	Display	Notes
1	CHK?	Hold MODE (↑) until display shows "CHK?". To activate, press TARE (↵). To deactivate, either press ZERO (⇐) or allow the system to time out after 8 seconds.
1a	PrEV	If activated, the display shows "PrEV". Press TARE (↵) to use previous settings, or press ZERO (⇐) to set new values.

Setting Limits

Step	Display	Action
2	Hi	Use ZERO (⇐) to move the flashing digit and MODE (↑) to increase the value. Confirm with TARE (↵).
3	LoW	Follow the same process as in Step 2.

Setting Alarm Mode

Step	Display	Action
4	bEEP	Display shows "bEEP" briefly, then changes to "bb-no". Use MODE (↑) or MR (↓) to choose the alarm mode. Confirm with TARE (↵).

Note: The "bEEP" display indicates that you are entering the Alarm Mode settings. The following options will be available:

Alarm Modes

Alarm Mode	Description
------------	-------------

bb-no	No beep for any result.
bb-Go	Beeps when the result is within range.
bb-H.L	Beeps when the result is out of range.
bb-Hi	Beeps when the result is above the upper limit.
bb-Lo	Beeps when the result is below the lower limit.

Important Notes

- Measurement Units: Check Weighing can be used in g, kg, lb, PCS
- Minimum Activation: 20d in weighing mode, 2pcs in counting mode.
- Limit Validation: Lower limit must be less than the upper limit.

Percentage Weighing

Use the percentage mode to measure the weight of a reference item, then display the weight of the test item as a percentage of the reference item's weight. Ideal for tasks like weight inspection or ingredient ratio adjustments.

Requirements: The sample value for 100% must be equal to or above 1000d.

Instructions:

Step	Operation	Display/Indicator
1	Ensure the scale is zeroed	"0"
2	Press [TARE] to eliminate the weight of the container if present	"0"
3	Select 'Pct' as your unit of measurement by pressing [MODE]	"Pct"
4	Hold down [ZERO⇒] to initiate 100% sampling mode	"S=100"
5	Place the reference item (representing 100%) on the scale	'OK' lights up
6	Press [TARE] to confirm the setting and exit the sampling mode	"100 Pct"
7	Start using the percentage measurement function by placing your test item on the scale	Displays weight of test item as a percentage of reference item's weight

Note: If no item is placed or if the weight is too light, the 'Lo' indicator will light up.

RS-232 Connection (D-sub 9 pin female connector)

Pin Connection (Computer Side):

Pin	Configuration
1	DCD
2	RXD
3	TXD
4	DTR
5	GND
6	DSR
7	RTS
8	CTS
9	NC

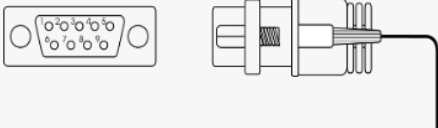

The diagram shows a D-sub 9 pin female connector on the left and a D-sub 9 pin male connector on the right. The male connector is connected to a cable with a right-angle bend. The female connector has nine pins arranged in a 2x5 grid, with the 5th pin (GND) being the longest. The male connector has nine pins of varying lengths, with the 5th pin being the longest. The cable is connected to the 1st, 2nd, 3rd, 4th, 5th, 6th, 7th, and 8th pins of the male connector.

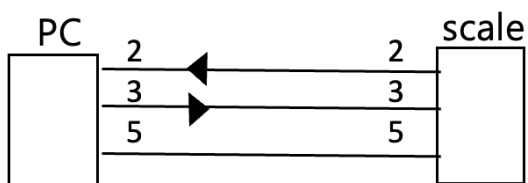

At a minimum, you can only connect to Pin 2, 3, and 5

Pin 7 & 8 are internally connected (short-circuited)

Internal Setting Function

The table below lists the internal functions available, some of which are only authorized for technical personnel.

Do not attempt to disassemble any certified scales or any sealed structures

Display	Function Setting	Access (Note 1)
F0 *	Zero tracking parameter setting (0.25/0.5/1.0/2.0d)	Password or Legal restrictions
F1	1. View ADC value 2. Key test	Open (uncontrolled)
F2	1. Firmware version and display check 2. Brightness adjustment (darkest / dark/medium/bright / brightest)	Open (uncontrolled)
F3*	Specification setting (for trade/ maximum weighing + division value/calibration)	Password or hardware lock control
F4	Auto shutdown setting (ALL.on or wait minutes)	Open (uncontrolled)
F5	Measurement unit menu (on/OFF + kg/lb/g....)	Open (uncontrolled)
F6	Digital filter parameter selection (anti-shock intensity 0~6 level)	Open (uncontrolled)
F7	UART1: Communication protocol setting of serial communication interface	Open (uncontrolled)
F8	UART1: Peripheral equipment menu and output mode/data format selection for serial communication connection.	Open (uncontrolled)
F9	Tare mode menu: manual/automatic/continuous/packaging	Open (uncontrolled)
F10*	Startup zeroing range: (In.=OFF/10/20/30)	Password or Legal restrictions
F11	Open accumulation function? (Accumulation key is only used as print key)	Open (uncontrolled)

F12	Hold function setting: OFF/ Lock.H(auto)/ Lock.d (1~9d)/Lock.W($\pm 0.1 \sim \pm 20.0\%$ (display value))	Password or Legal restrictions
F14	UART2: Communication protocol setting of serial communication interface	Open (uncontrolled)
F15	UART2: Peripheral equipment menu and output mode/data format selection for serial communication interface.	Open (uncontrolled)
F16	Password setting (default value=0 or 00000 ; no password)	(Password control), Note 2
F17	Set and calibrate date clock (Time and date setup)	Password control
F18	Beep mode [Sd. on /oFF]	Open (uncontrolled)
F19	Expanded display mode (for verification only)	F3:Functional when legal
F20	C.G. Setting of gravity value for calibration ground	Viewable (Password or hardware lock control)
F21	U.G. Setting of gravity value for the place of use	Viewable (Password or hardware lock control)
F30	Display refresh rate [dSp. 0 /1/2/3/5/ 9]	Password control
F32	Stable Condition Selection	Password or Legal restrictions
F33*	Key Stability Control	Password or Legal restrictions
F35*	Zero near residual weight zeroing range [0 /1/2/3/5 d]	Password or Legal restrictions
F36*	Weight value drift compensation [0.0~2.0d]	Password or Legal restrictions
F38	Power saving function (backlight on time Off / 5/10/20/ON)	Open (uncontrolled)
F51	IR SENSOR Setting & Distance selection!	Password control
F100	Reset to factory settings	Password or hardware lock control

When F3.TYPE is set to LEGAL, access to several functions, including F0, F10, F12, and F32 to F36, will be restricted and they will not appear in the main menu. Function F19 will remain active under these conditions. It is also mandatory to set F0 to 0.5d, limit F10 to 20%, set F33 to YES, and set both F35 and F36 to 0.

Note 1: LOCK PIN (Hardware Lock):

Purpose: Mainly used for certified scales, this feature locks specific functions tied directly to weighing, such as F3 (specification setting), as well as F19 to F21 and the calibration function.

Role: The LOCK PIN operates with the highest level of authority, managing the options linked to weighing performance.

Actions: Upon activation of the LOCK PIN, weight calibration execution and parameter changes for F0, F3, F10, F100 are disallowed (these won't be displayed). Nonetheless, F19 isn't controlled and can be run. F20 & F21 can be accessed for viewing but not for any alterations.

Note 2: Password Control (F16 Setup):

Purpose: This feature helps production line managers prevent unintended changes to the scales' advanced settings by operators.

Role: When enabled, it restricts access to most of the menu, especially weighing performance functions, unless the hardware lock is on.

Actions: With the LOCK PIN off, entry to settings F0, F3, F10, F16, F17, F19-F21, F33, F35, F36, and F100 requires a password.

Function Definitions and Parameter Settings

Step	Operation	Display/Indicator
1	Power on the device by pressing the [ON/OFF] key.	Power on sequence starts
2	Before the countdown ends, press the [TARE] key to enter internal settings mode.	Displays "F1" or "F0"
3	Use [▲] key to go to next option or [▼] key to go back to previous option.	The next or previous option is displayed
4	Confirm your selection and enter the parameter settings of the selected function by pressing the [TARE] key.	The parameter settings are displayed
5	In the submenu, use [▲] key to scroll through parameter options.	The parameter options are displayed
6	Confirm your selection by pressing the [TARE] key to proceed to the next option.	The next option is displayed
7	After setting all desired options, save them by pressing the [▶] key.	Displays "SAVE"
8	Confirm and save your changes by pressing the [TARE] key. If you do not wish to save the changes, press [▲] key.	Settings saved or discarded
9	**Important: Before exiting the internal function settings, ensure to save the changes. If the changes	---

are not saved, the device will retain the previous settings.
--

F0. Auto Zero Tracking (AZT):

Default setting is at 0.5d. Definition: A device that automatically maintains the zero indication within specified limits. Settings: Choose from [F0] [0.25d / 0.5d / 0.75d / 1d / 2d]. If the environment temperature changes significantly or the weighing cycle is long, leading to a non-zero state, you can opt for a larger parameter value.

F1. Offset:

Shows the ADC offset, vital for understanding weight signals in production and maintenance.

Definition:

Originating from the LOADCELL's signal, it's digitized and filtered to achieve optimal accuracy and stability, taking into account component and environmental factors.

Use:

In production and maintenance, this value evaluates the Loadcell signal, highlighting Offset, Span, stability, and potential drifts.

F2. Display Check and Brightness Adjustment:

The default setting is medium brightness. All display symbols will light up (backlight included for LCD type) and alternate with the program version code (for example: 1.xy). Adjust the display brightness using the [↑](#) key. There are five brightness levels to choose from to achieve optimal display visibility. Confirm your selection and return to the main menu by pressing the [TARE] key.

F4. Auto Shutdown:

Definition: If the scale is idle for a certain duration (no weight change or operation), the auto-shutdown mechanism is triggered to conserve power. You can select the auto-shutdown wait time or disable this feature entirely by choosing between ALL.on -> 5.oFF -> 10.oFF -> 20.oFF -> 30.oFF.

The displayed number represents the wait time in minutes for auto-shutdown. Please note, if set to 'ALL.on', the scale will never auto-shutdown unless manually turned off.

F5. Commonly Used Measurement Unit Settings:

Definition: This allows users to switch between or choose appropriate measurement units using the [MODE] key during weighing sessions. To enable or disable a measurement unit, navigate to [Unit] -> [on or oFF]

F6. Digital Filter:

This digital filter is designed to mitigate the effects of weight oscillation.

Definition: Depending on the level of environmental disturbance, choose an appropriate anti-disturbance coefficient to ensure the display value is timely and stable. Navigate using [F6] -> [Filt. 0/1/2/3/4/5/6]. The higher the value, the stronger the anti-disturbance coefficient and the more stable the display, but the response may be slower.

*Tip: For weighing animals, it's recommended to set F6 to 'Filt6' and F32 (stability width) to 'St.= 3~5d'.

F7 Setting the Transmission Mode

Action	Options	Description
Enter Transmission Mode	Press [TARE] when F7 is displayed.	This opens the menu for communication protocols.
Choose Communication Protocol	OFF / RS232 / RS485	Different types of communication protocols. Use [▲]/[▼] to select and [TARE] to confirm.
Set Baud Rate	2400 / 4800 / 9600 / 19200 / 38400 / 115200 bps	The speed at which data is transmitted. Use [▲]/[▼] to select and [TARE] to confirm.
Set Protocol	N81/E81/O81/N71/E71/O71	Defines how data is framed and error-checked during transmission. Use [▲]/[▼] to select and [TARE] to confirm.

F8 Configuring the RS-232 Connection

Action	Options	Description
Enter RS-232 Configuration	Press [TARE] when F8 is displayed.	This opens the menu for external device selection.
Choose External Device	PC (Computers) / TSC (Label Printers) / SH-24 (24-Pin Dot Matrix Printers)	The type of device you're connecting to. Use [▲]/[▼] to select and [TARE] to confirm.
Set Transmission Type	Conti. / Conti.S / Auto. / Manu / CMd.	Determines how data is sent from the scale to the device. Use [▲]/[▼] to select and [TARE] to confirm.
Set Data Format	SER1.0SER1.4 / SER2.0...SER2.4	The structure of the data being transmitted. Use [▲]/[▼] to select and [TARE] to confirm.

Note on Transmission Types:

- Conti.: Continuous transmission, regardless of weight stability. This mode also accepts CMd instructions.
- Conti.S: Continuous transmission, but only after the weight is stable. Zero values are excluded. This mode is applicable only for weights between 10d and Max.

- Auto.: Automatic transmission occurs once, but only after the weight is stable. Zero values are excluded. This mode is applicable only for weights between 10d and Max.
- Manu.: Press the [Accumulate M+] key to send weighing data once.
- CMd.: The device executes the corresponding action after receiving a command from a PC or another terminal.

Example:

Manu (Manual transmission)

Format Set to Ser.1.x:

In this setting, press the [M+] button to transmit a transaction record. Please note that the total accumulated weight will not be displayed. An essential point to keep in mind is that, in the absence of a tare weight, the gross weight equals the net weight.

Format Set to Ser.2.x:

In this setting, use the [M+/MCr⇐] button to transmit a single data set. To send the total accumulated weight, first press the [MR] button, then press the [M+/MCr⇐] button. This action will send the total weight and simultaneously clear the weight from memory.

S/N	WEIGHT (kg)	UT	Remarks
1	100.02	H	Press [M+/MC] to send data
2	99.01	G	
3	1210.05	H	
4	10.12	L	
Total	9876.10		Press [MR] then [M+/MC] to send the total weight and clear the weight from memory

AUTO: Automatic Transmission Modes

Format Set to Ser1.x:

In this automatic mode, the data will be transmitted once the weighing result is stable. Please note that the accumulated total value cannot be printed in this format. When the display stabilizes and surpasses 20e, the indicator will automatically send a single weighing result.

Example Outputs:

ST, NT, 100.01kg

ST, NT,- 100.01kg
US, GS, 1000.01kg

Format Set to Ser2.x:

When the display stabilizes, the indicator will automatically send a single weighing result. Press the [MC] button to clear the memory and print the total value.

S/N	WEIGHT (kg)	UT	Remarks
1	100.02	H	Indicator automatically sends single data when stable
2	99.01	G	
3	1210.05	H	
4	10.12	L	
Total	9876.10		Press [MC] to print total (only when F11 is set to ACC-on)

When real-time clock function (F17) is enabled:

When the real-time clock function is enabled (set as 'rtC.on'), the date and time values will be included in the RS-232 data stream:

Format Set to Ser1.x:

2022/07/25 10:30:21 ST, NT, 100.01 g
2022/07/25 10:30:39 ST, NT, 210.00 g

Format Set to Ser2.x:

The date and time precede the weight data table, which shows individual and total weights.

Date & Time: 2022/07/25 10:31:21

S/N	WEIGHT (g)
1	100.02
2	99.01
Total	199.03

F9: Auto/Continuous Tare

This setting allows you to enable or disable the automatic or continuous taring of the first weight after the display stabilizes.

Menu Path: [F9] -> [tr.oFF] / [tr.on] / [tr.Cnt] / [tr.PACK]

The total tare value should not exceed the maximum weight capacity

Settings	Functionality
tr.oFF	Auto taring is disabled.
tr.on	As soon as the scale has a steady reading, the initial weight is automatically tared.
tr.Cnt	Performs automatic taring after the display stabilizes (unlimited times).
tr.PACK	After stabilization, the first piece is automatically tared. Subsequent taring is only performed if the CHECK-OK condition is met. This setting is applicable for composite multi-piece packaging.

F10. Initial Zero-Setting Range

This setting allows the device to automatically set the indication to zero when the instrument is switched on and before it is ready for use.

Menu Path: [F10. IZS] -> [In.=OFF/10/20/30/50/100]

The scale sets its zero point at startup based on its calibration. If the load exceeds the allowable range, it won't zero and will display 'Err.4'. If unresolved, it will show 'P-OFF' after one minute and then shut off. If the overload is removed during this period, the scale will zero and enter standby mode.

Settings	Functionality
In.= OFF	Based on the calibration zero point, there are no restrictions, and it goes straight into standby mode showing the current weight.
In.= 20	Based on the calibration zero point, only if the load is within $\pm 20\%$ of the maximum weight capacity, will it allow for initial zero-setting and transition into standby mode.
In.= 10/30/50/100	These settings work similarly to 'In.= 20', but with the respective percentages.

F11. Accumulation Functionality

The M+ button combines the accumulation and print functions by default, performing both simultaneously. This can be changed by setting [ACC.oFF] to disable the accumulation functionality, turning M+ into a dedicated PRINT key.

F12. Hold function

The HOLD function temporarily retains the display value for user inspection or record keeping. During this time, the data transmission output through the interface corresponds to

the displayed value. When this HOLD mode is active, the display will blink to indicate its status.

Note: The display hold function is not supported when the type is set to "Legal".

Mode	Description	Conditions for Lock/Unlock	Default & Range	Applications/Remarks
OFF	Disables the HOLD function	-	-	-
Lock.H (Auto Hold)	Automatically locks the displayed weight value once it stabilizes	Unlocks when unloaded (less than Min)	-	General weighing
Lock.d (Lock in range)	The weight value locks when the weight change is within a certain range	Locks when the weight variation is less than $\pm xd$; Unlocks when more than $\pm xd$; Locks again when less than $\pm xd$	Default: 5d Range: 1~9d	Small scale applications
Lock.W (Lock in weight)	The weight value locks when the weight change is within a certain percentage of the display value	Locks when the weight variation is less than $\pm x\%$ (display value); Unlocks when more than $\pm x\%$; Locks again when less than $\pm x\%$	Default: 1.0%; Range: $\pm 0.1\%$ to $\pm 20.0\%$ (display value)	Any application that requires % change
Peek.H (Peak Hold)	Only the maximum weight value during the weighing process is displayed	Resets after unloading (less than Min)	-	Force measurement or measuring breaking strength of ropes (recommend setting F6 (Digital Filter) to Filt.0 or Filt.1)

Notes:

- For animal weighing, it is recommended to set F6 (Digital Filter) to Filt6 and F32 stability control to 2~3d.
- It is advised to turn off the F9-AutoTare function when using the F12 automatic HOLD function.

F14: UART.2 transmission protocol

This function is the same as F7.

F15: UART.2 Transmission/Format

This function is the same as F8.

F16: Password setting

Important: Don't forget your password! If forgotten, you'll lose access to certain functionalities, including F3 and F17. By default, no password (set as '0') means no restrictions. However, once a new password is set, a forgotten password can only be reset by professional servicing. Secure your device's full functionality by safeguarding your password.

[Default value = 0, which means there is no password control]

Steps: [F16.Pin] → [O.Pin] → [XXXX] → [n.Pin] → [YYYYY] → [F17]

Step Code	Step	Instruction	Additional Information
F16.Pin	-	Start of the password setting process	Press the [TARE] button to enter this setting.
O.Pin	a.	Old password [O.Pin] appears for 1~2 seconds, then flashing display [0]. This is a prompt for you to enter your old password.	Use the [▲] or [▼] key to increase or decrease the old password value, then press [TARE].
-	-	If you don't want to change the password, press [⇐] to exit	This option allows you to abort the password change operation
XXXX	b.	Enter old password (up to 6 digits), then press [↵] confirmation key	Use the [▲] or [▼] key to increase or decrease the old password value, then press the confirmation key "".
n.Pin	c.	Display shows "n.PIn"	This is a prompt for you to enter your new password
YYYYY	d.	If you want to change the password, press [TARE] otherwise press [⇐] to exit	Here, you decide if you want to proceed with the password change
-	e.	Enter new password (up to 6 digits) using number keys, then press [TARE]	Use the [▲] or [▼] key to increase or decrease the new password value, then press [TARE]
F17	-	End of the password setting process	-
-	-	Save changes	If changes were made, save them by pressing the [▶] key to display "SAVE" on the screen. Confirm and save your changes by pressing the [TARE] key, or choose not to save

			the changes by pressing the [▲] key.
-	-	Note: After setting the password, the F3 weighing specification setting /calibration function and the F17 time setting will be locked (controlled)	This is a caution note. Please remember your new password to avoid loss of access to F3 and F17 functions

F17 Setting and Calibrating Date & Time

Activating Real-Time Clock (RTC): Toggle RTC on or off by choosing between [rtC.on] or [rtC.oFF] in [F17.dAt]. If [rtC.on] is selected, the time will be included in the output data.

Time Setting: Set the time in a 24-hour format (hh:mm:ss). When [12:30:30] appears on the display, use the [▲ or ▼] keys to adjust the flashing value and the [▶] key to move to the next value. Press the [TARE] key to confirm your time settings.

Note: Once all settings are confirmed, you will be taken to the main menu [F18].

Quick Guide:

Steps	Choices	Controls	Actions
1. Activate RTC	[rtC.on] / [rtC.oFF]	[▼ or ▲]	Toggle RTC on or off
2. Choose Date Format	[yy:mm:dd] / [dd:mm:yy] / [mm:dd:yy]	[▼ or ▲]	Select format
3. Set Date	e.g., [22:06:15]	[▲ or ▼] to change the value, [▶] to move	Set date
4. Set Time	e.g., [12:30:30]	[▲ or ▼] to change the value, [▶] to move	Set time

Remember, use the [TARE] key to confirm your settings in each step.

F30. Display Update Rate:

Choose the speed at which the weight value is refreshed on the display.

- 1: Stable Display - Updates only when weight is stable.
- 2: 1's Update - Updates once per second.
- 3: 600ms Update - Updates every 600 milliseconds.
- 4: 400ms Update - Updates every 400 milliseconds.
- 5: 200ms Update - Updates five times per second.
- 9: Fastest Update - Real-time updates, approximately 10 times per second.

Remember, a faster rate captures rapid weight changes, while a slower rate offers more stable readings.

F32. Stable Condition Selection

This setting defines what's considered a stable weight reading. It affects the operations of the ZERO, TARE, M+, Print keys and the transmission function of the output interface.

- ST.= 1d to 5d: Defines stability. Weight changes within this range are considered stable.

F33. Key Stability Control

This setting decides whether operations (ZERO, TARE, M+, Print) need a stable condition (defined in F32) to be executed.

- kEy.St.y: Operations can be performed only when the weight is stable.
- kEy.St.n: Operations can be performed regardless of weight stability (not available when TYPE=Legal).

F35. Auto Zero-Reset Range

Not applicable in Legal mode

Definition: This setting controls the automatic reset to zero for residual display values near the zero point. These residual values could be due to inherent properties of the load cell, signal offsets, or span. They may persist particularly in high-resolution settings (n>30,000d).

Options: [F35] -> [rz.= 0d] ... [rz.= 5d]. You can set the range within which residual values will be forced to zero. For example, if set to 5d, any residual value within +/- 5d of zero will automatically be reset to ZERO.

F36. Weight Drift Compensation (Excluded in Legal mode)

Definition: Auto-adjusts for "drift" or slow, constant weight changes due to environmental factors.

Use: Activated under stable conditions (based on F32), with a max adjustment frequency of once per second, and adjustment magnitude of 0.5d max.

Settings: Set the drift range to trigger compensation (0.0/0.25/0.5/1.0/2.0d).

F38. Power-Saving Backlight Settings

- Define the amount of time (in seconds) before the backlight turns off after stabilization, helping save energy.
- Options: bl.oFF -> on -> bL.5 -> bL.10 -> bL.20
- bL.on keeps the backlight constantly on, bL.xx turns off the backlight xx seconds after stabilization.
- bL.oFF turns off the backlight completely but doesn't affect check weighing functions.

F51. Infrared Sensor (IR) Function Selection

The infrared sensor can detect the presence of a hand or any object located within a range of approximately 2-3 cm in front (or above) of the sensor. The actual operating distance may vary based on the reflective characteristics of the object. In case of abnormal operation

under special circumstances, the sensor can be deactivated. The infrared sensor settings are available for customization:

[Ir.Off] no function, [Ir. tArE] tare, [Ir.MOdE] function/unit conversion, [Ir. ZErO] zeroing, [Ir. Pr] printing/accumulation, [Ir. MR] display.

F100. Factory Reset

Restore all settings to their original factory values.

Useful for starting fresh or after updating the firmware to ensure smooth performance.

Steps:

1. Find and select 'F100' in the menu.
2. Confirm the reset by pressing [TARE].
3. To cancel, press [▼] or power off the device.
4. Save current settings by pressing and holding [ZERO].

Maintenance and Care Guidelines

- Do not attempt to open or repair the scale yourself; seek assistance from qualified technicians.
- Keep an eye on the operating environment to avoid excessive humidity and extreme temperatures.
- Use the provided original charger for charging purposes.
- When the battery indicator starts flashing, charge it immediately to prevent permanent damage to the rechargeable battery.
- After weighing, avoid leaving items accumulated on the weighing platform to prevent damage to the weight sensor.
- For cleaning, use a damp cloth to clean the scale body. The stainless-steel platform can be detached for cleaning.
- Choose mild cleaning agents and avoid excessive water.
- Do not use any chemical substances or alcohol for cleaning.
- If you're unsure about proper scale maintenance, contact your dealer for further assistance.